

Quality Inspection System

Safeguard your quality

Vision inspection technology system costs have come down and capabilities have dramatically increased. Engenesys can effectively integrate a system into your production line to ensure your product is 100% to spec. Whether you need to inspect parts before they go to the next operation or into their final box, we design a solution that works.

For both stepped or continuous flow processes, we have the experience to apply the proper camera, lighting and control system to check for multiple defects. Inspection can include feature quality, measurement, reading text and general part presence. One camera can replace numerous electronic sensors. Contact us to learn more.

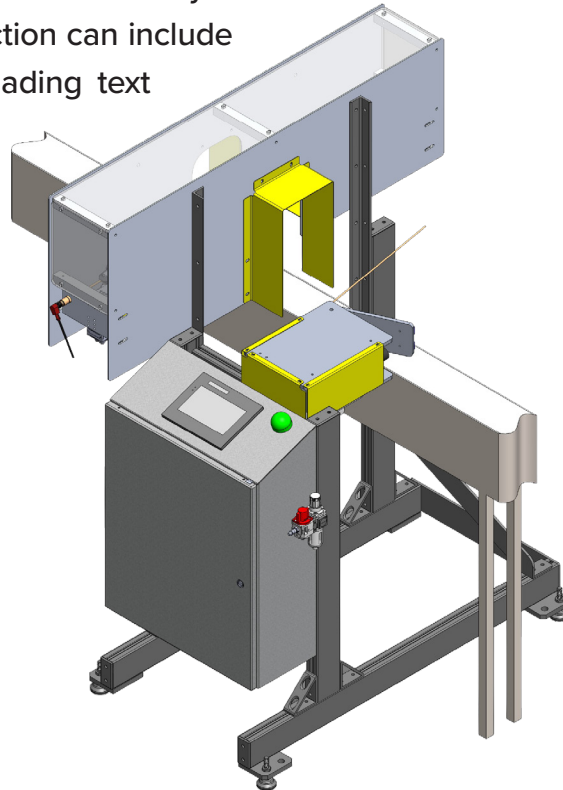

Product Formats



Trays



Bottles



Pouches



Cartons



Jars

AQI Technical Specifications

SPEED	Up to 100 per minute <i>Consult factory for higher speeds</i>
INSPECTION TYPES	Barcode Scan 2D Vision 3D Vision
CONVEYOR HEIGHT	30" - 60"
POWER	110V, 50/60 Hz
AIR	15 SCFM @ 80psi

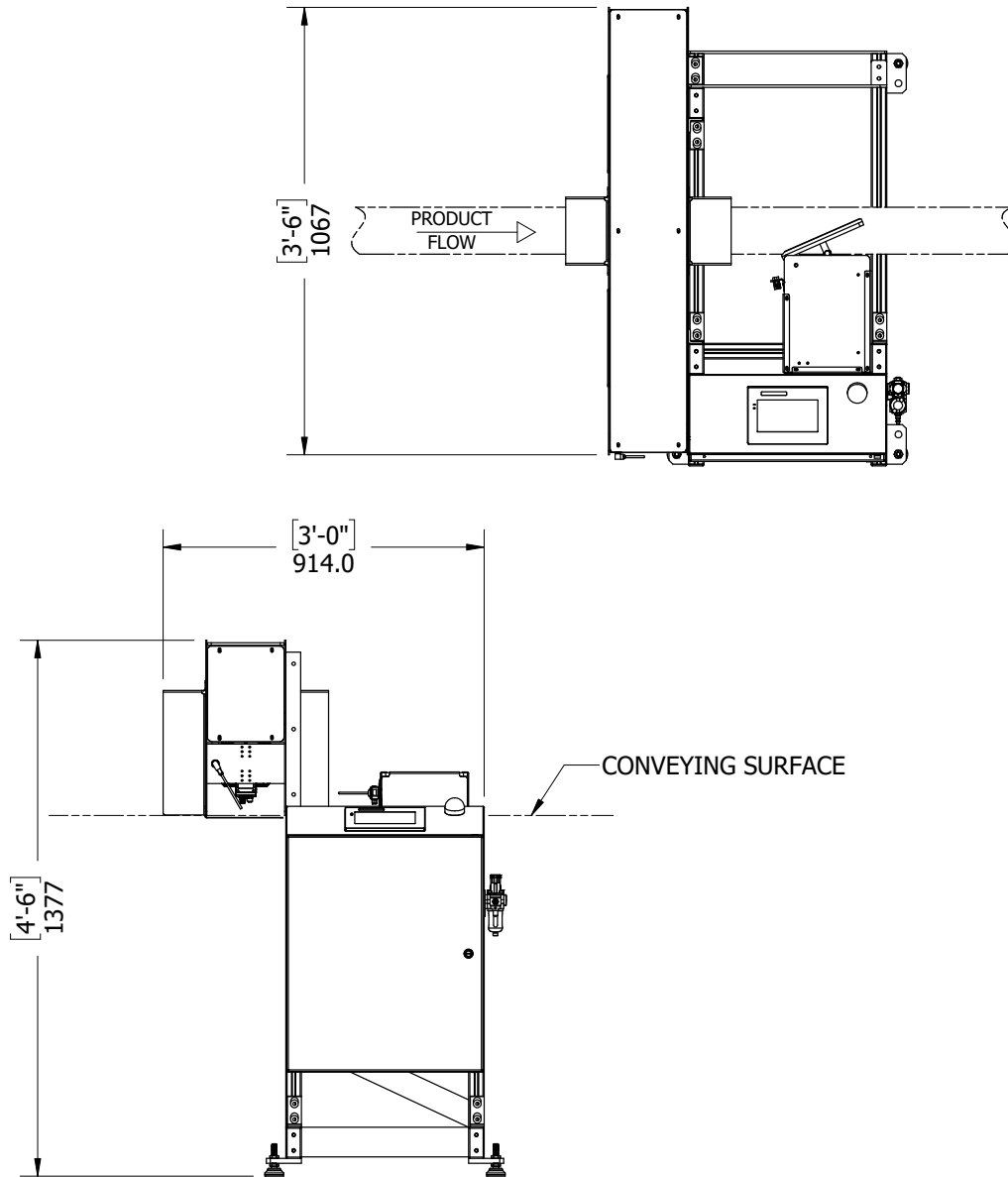

FEATURES AND BENEFITS:



- Line side alignable base
- Touch screen HMI
- Tailored inspection housing
- Multiple reject mechanism options
- Configurable for quick delivery
- Product flow metering option

2D Vision

- Presence / Absence
- Quality Inspection
- Gauging / Measurement
- OCR / OCV

3D Vision

- Dimensional Verification
- Gauging / Measurement
- Profile Confirmation

Barcode Reading

- 1D and 2D Codes
- High Speed Match String Verification

Deep Learning / AI

- Complex Inspection with Learning Tools
- Part to Part Variation
- Assembly Verification
- Defect Detection